

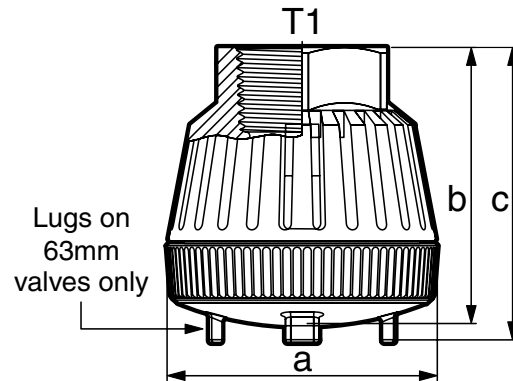

Email: info@hansenproducts.com
 Website: www.hansenproducts.com

Hansen Foot Valve Dimensions

Product Code	T1 BSPT (DN*)	a mm	b mm	c mm
FV25	25mm (1")	69	72	NA
FV32	32mm (1 1/4")	87	88	NA
FV40	40mm (1 1/2")	99	99	NA
FV50	50mm (2")	123	120	NA
FV63	63mm (2 1/2")	152	NA	156



Hansen Foot Valve Flow Chart

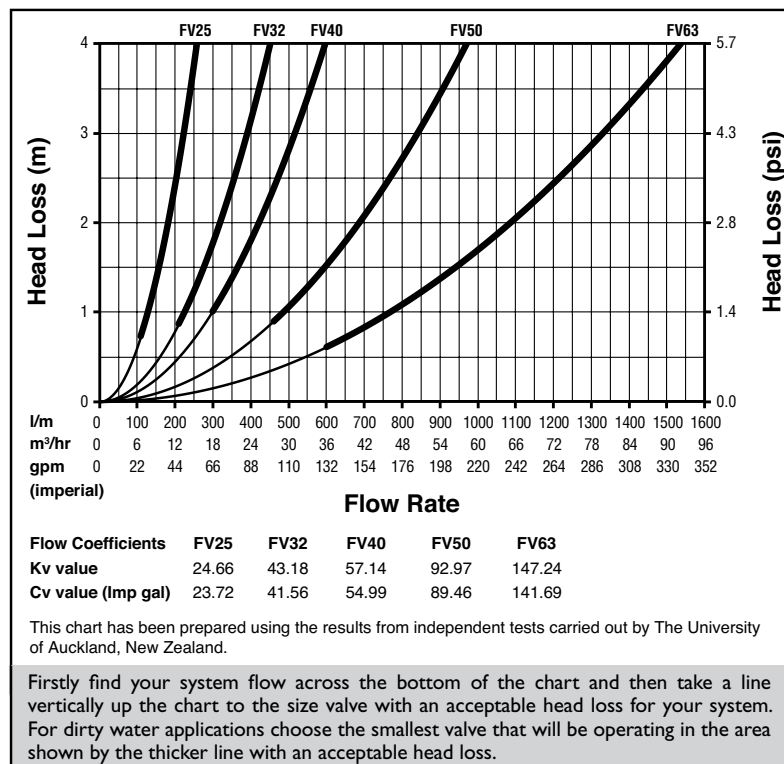

Standards & Approvals

AS/NZS 4020 Hansen *Foot Valves* have met the requirements of AS/NZS 4020 Australia & New Zealand drinking water test standard. See our website for details.

For further technical information, including chemical & temperature specifications, please visit our website: www.hansenproducts.com



GENERAL
Marine
 SERVICES

156 Beaumont Street · Westhaven · Auckland · New Zealand
 Sales Ph +64 9 309 0048 · sales@generalmarine.co.nz
 Service Ph +64 9 368 0938 · service@generalmarine.co.nz

www.generalmarine.co.nz